

INDUSTRIAL DIESEL ENGINE

KUBOTA V3 SERIES (4-cylinder)

V3600-E3B



RATED POWER

49.8kW@2600rpm

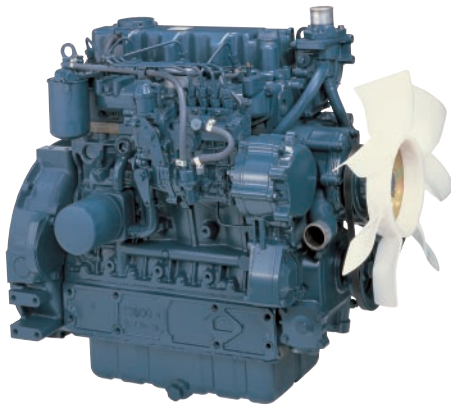

Photograph may show non-standard equipment.

PERFORMANCE CURVE

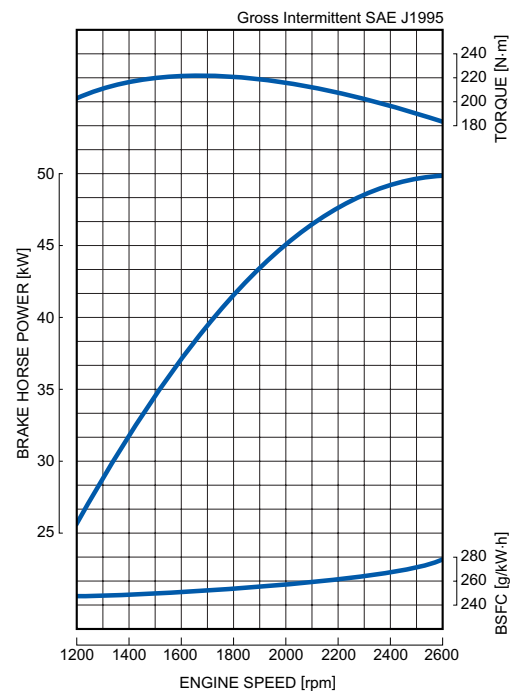

FEATURES and BENEFITS

Emissions

- The Kubota V3600 naturally aspirated engine complies with EPA Interim Tier 4 (Option1) emissions regulations, which are the most stringent in this class. This engine also complies with EU Stage IIIA requirements. It offers the benefit of one year longer validity than Tier3. Therefore, this engine is good through the end of 2012 in both the North American and European markets, which would save engineering resources for the future Tier levels.
- Utilizing the low NOx characteristics of IDI engines, the V3600 NA engine complies with the latest emissions regulations without devices such as EGR system or turbocharger.

Durable Power

- The Kubota V3600 engine is a new high power density engine with the same footprint as the V3300 engine, however with a larger displacement.

Clean and Quiet Power

- Kubota's original E-TVCS (Three Vortex Combustion System) has been improved. The airflow, combustion chamber and piston recess were optimized to provide a 25% lower particulate matter (PM) level, resulting in a better condition compared to engines that only meet EPA Tier 3 regulations in this class.

Option

- Fan positions are available in two heights to adapt to various equipment configurations.

GENERAL SPECIFICATION

Model		V3600-E3B
Emission Regulation		Interim Tier 4 / Stage III A
Type		Vertical 4-cycle Liquid Cooled Diesel
Number of Cylinders		4
Bore	mm (in)	98 (3.86)
Stroke	mm (in)	120 (4.72)
Displacement	L (cu.in)	3.620 (220.9)
Combustion System		IDI
Intake System		Naturally Aspirated
Maximum Speed	rpm	2600
Output: Gross Intermittent	kW	49.8
	hp	66.8
	ps	67.7
Direction of Rotation		Counterclockwise Viewed on Flywheel
Oil Pan Capacity	L (gal)	13.2 (3.49)
Starter Capacity	V-kW	12-3.0
Alternator Capacity	V-A	12-60
Length	mm (in)	745.0 (29.33)
Width	mm (in)	536.0 (21.10)
Height (1)	mm (in)	741.5 (29.19)
Height (2)	mm (in)	257.0 (10.12)
Dry Weight	kg (lb)	264 (582.0)

*Specification is subject to change without notice.

*Output: Gross Intermittent SAE J1995

*Dry weight is according to Kubota's standard specification.
When specification varies, the weight will vary accordingly.

DIMENSIONS

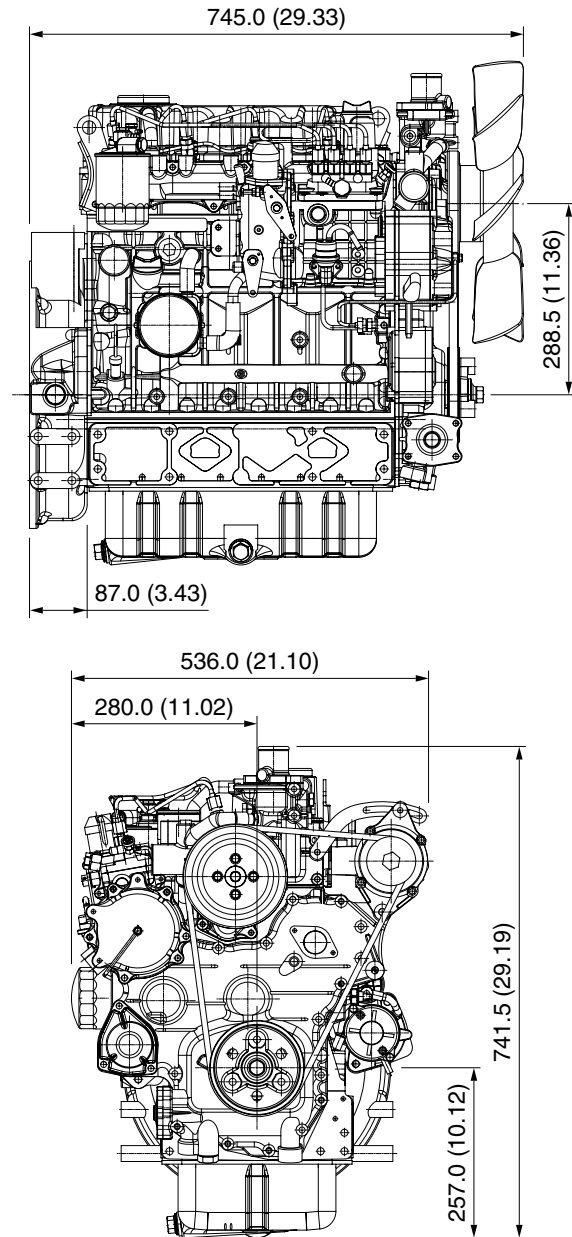

Your Driving Force
KUBOTA ENGINE

KUBOTA Corporation

2-47, Shikitsuhigashi 1-chome, Naniwa-ku, Osaka, 556-8601 Japan
Fax: 06-6648-3521

<http://www.engine.kubota.ne.jp>