

INDUSTRIAL DIESEL ENGINE

KUBOTA 05 SERIES (4-cylinder)

V1505-E3B



RATED POWER

26.2kW@3000rpm



Photograph may show non-standard equipment.

PERFORMANCE CURVE

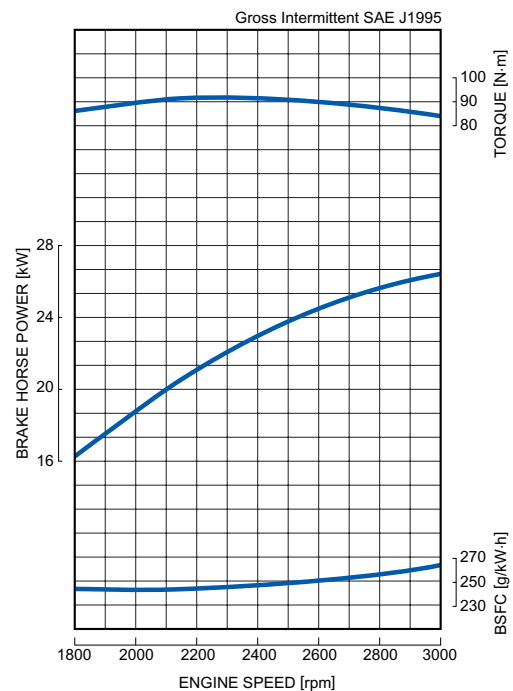

FEATURES and BENEFITS

Emissions

- The V1505 naturally aspirated engine complies with EPA Interim Tier 4 emissions regulations that are effective through the end of 2012. This engine also complies with EU Stage IIIA requirements that are effective through 2012 and beyond in the European market.

Durable Power

- The Kubota 05 Series is an established leader in its horsepower range and has been the preferred power source of various industrial equipment manufacturers.
- The V1505 NA engine offers a seamless transition from Tier 2 to Interim Tier 4 by maintaining the same footprint and hardware mounting points with only slight performance changes from the Tier 2 engine.

Clean and Quiet Power

- Kubota's original E-TVCS (Three Vortex Combustion System) has been improved. The airflow, combustion chamber and piston recess were optimized to provide a 50% lower particulate matter (PM) level, the same stringent level as above the 37kW class (EPA Interim Tier 4 Option 1).

GENERAL SPECIFICATION

Model		V1505-E3B
Emission Regulation		Interim Tier 4 / Stage III A
Type		Vertical 4-cycle Liquid Cooled Diesel
Number of Cylinders		4
Bore	mm (in)	78.0 (3.07)
Stroke	mm (in)	78.4 (3.09)
Displacement	L (cu.in)	1.498 (91.41)
Combustion System		IDI
Intake System		Naturally Aspirated
Maximum Speed	rpm	3000
Output: Gross Intermittent	kW	26.2
	hp	35.1
	ps	35.6
Direction of Rotation		Counterclockwise Viewed on Flywheel
Oil Pan Capacity	L (gal)	6.0 (1.59)
Starter Capacity	V-kW	12-1.2 [US] / 12-1.4 [EU]
Alternator Capacity	V-A	12-40
Length	mm (in)	591.3 (23.28)
Width	mm (in)	396.0 (15.59)
Height (1)	mm (in)	607.0 (23.90)
Height (2)	mm (in)	232.6 (9.16)
Dry Weight	kg (lb)	110.0 (242.5)

*Specification is subject to change without notice.

*Output: Gross Intermittent SAE J1995

*Dry weight is according to Kubota's standard specification.

When specification varies, the weight will vary accordingly.

DIMENSIONS

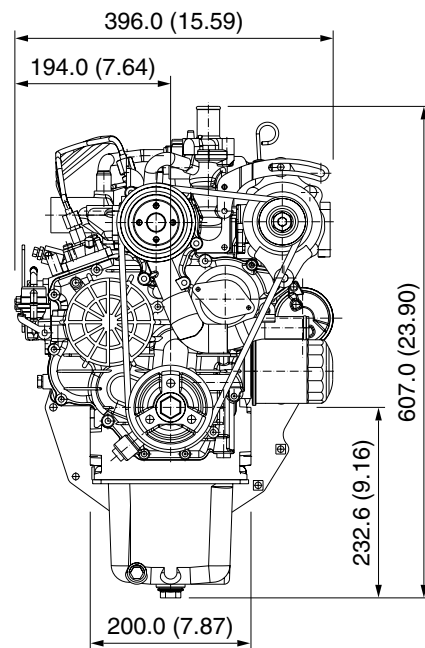
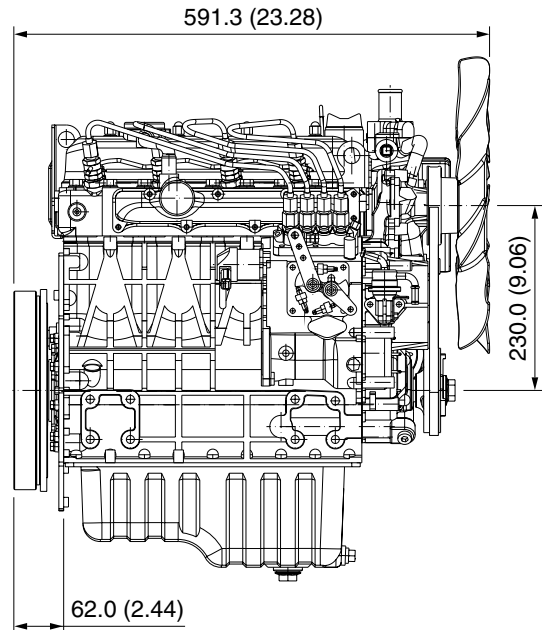

KUBOTA Corporation

2-47, Shikitsuhigashi 1-chome, Naniwa-ku, Osaka, 556-8601 Japan
Fax: 06-6648-3521

<http://www.engine.kubota.ne.jp>

Your Driving Force
KUBOTA ENGINE